

CLEANFIX TW411 SEV

Inhaltsverzeichnis

PDF erstellt am: 06.03.2024 17:15



TW 411

Saugset

Tuyau d'aspiration set

Suction set

B 5 / ST 5

Deckel-Gehäuse

Capot-Bâti

Cover-Housing

B 1 / ST 1

Saugmotor-Pumpe

Moteur d'aspiration-Pompe

Vacuum motor-Pump

B 2 / ST 2

Einbau Saugmotor-Pumpe

und Netzleitung

Montage de la moteur

d'aspiration-pompe et

Cable d'alimentation

Pump assembling-vacuum motor

and Electrical connection

B 4 / ST 4

NDSX-Pumpe

Pompe-NDSX-

Pump-NDSX

B 3 / ST 3

Saugset

Tuyau d'aspiration set

Suction set

B 5 / ST 5

Stromlaufplan

Diagramme électrique

Wiring diagram

B 6 / ST 6

CLEANFIX TW411 SEV

Deckel-Gehäuse

PDF erstellt am: 06.03.2024 17:15



TW 411 / TW 412

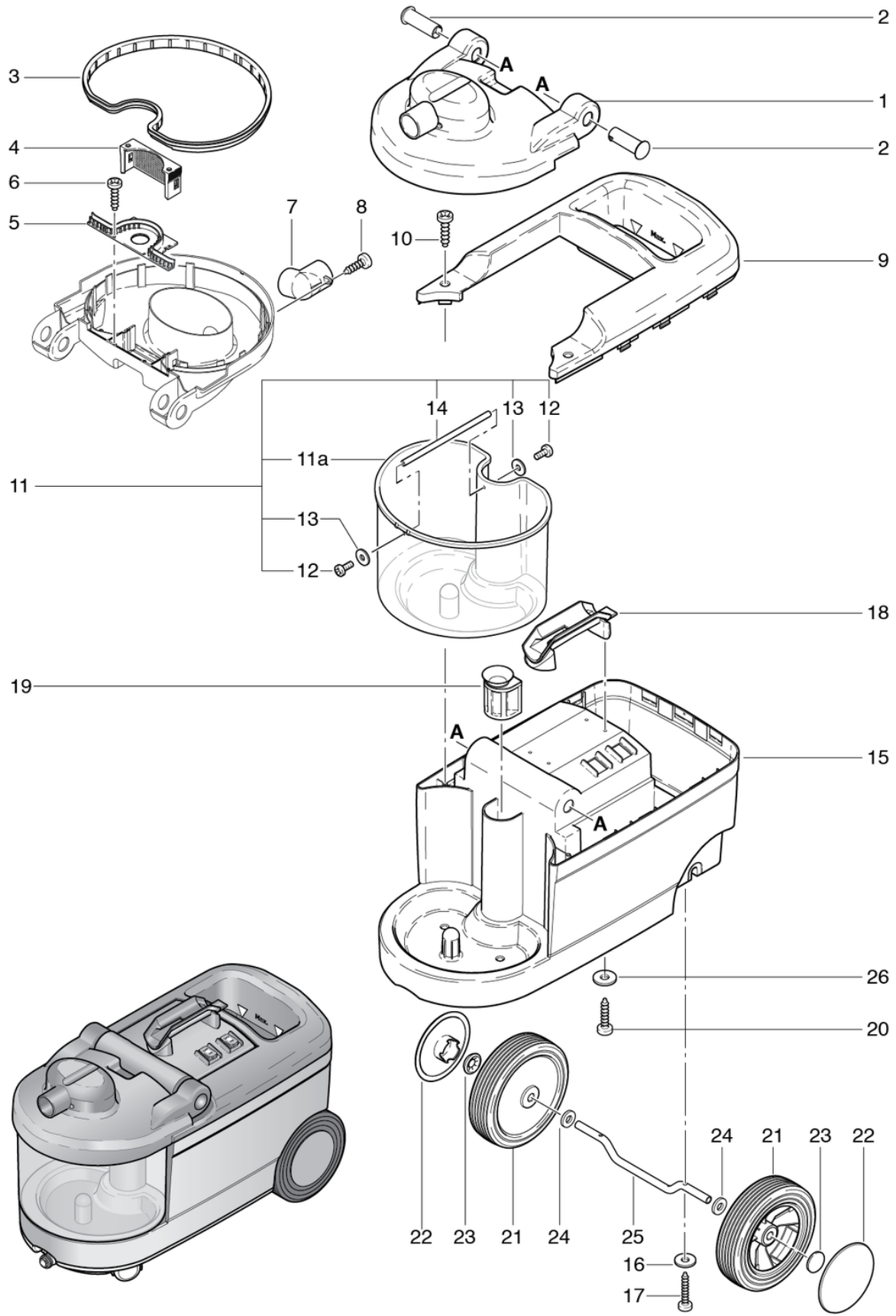

Pos.	Artikel-Nr.	Ersatzteil	Preis
1	043.201	Deckel anthrazitgrau	CHF 28.65
2	043.504	Gelenkbolzen	CHF 2.20
3	043.202	Dichtung	CHF 10.40
4	043.205	Filter	CHF 2.60
5	043.204	Deckel Einsatz	CHF 2.20
6	P516F	Schraube WN 1451 K30 x 16 St vz	CHF 2.20
7	043.207	Stutzen natur transparent 45mm bearbeitet	CHF 7.40
8	P516A	Schraube WN 1452 K30 x 10 A2	CHF 2.20
9	043.502	Abdeckung anthrazitgrau	CHF 33.25
10	P516G	Schraube WN 1451 K40 x 16 St vz	CHF 2.20
11a	043.301	Wassereimer	CHF 57.20
11	043.300	Schmutzwassereimer	CHF 75.40
12	P475B	Schraube DIN 85 A M3 x 12 St vz	CHF 2.20
13	P497J	Scheibe DIN 9021 M3 3,2/9/0,8 St vz	CHF 2.20
14	043.302	Welle	CHF 9.70
15	043.510	Gehäuse TW411/412 rot	CHF 105.35
16	P497C	Scheibe DIN 9021 M4 4,3/12/1 A2	CHF 2.20
17	P516O	Schraube WN 1452 K40 x 25 St vz	CHF 2.20
18	043.503	Griff anthrazitgrau	CHF 7.25
19	043.505	Ansaugstutzen	CHF 7.50
20	P515X	Schraube WN 1452 K40 x 20 St vz	CHF 2.20
21	380.135	LaufRad kpl.	CHF 21.00
22	300.242C	Radkappe 180-88/150-94 anthrazitgrau	CHF 2.20
23	P499LB	Ring Starlock NW 12 o. Kappe A2	CHF 2.20
24	P510P	Scheibe DIN 522 M12 13/28/4 St vz	CHF 2.20
25	043.501	Achse	CHF 40.05
26	P496G	Scheibe DIN 9021 M5 5,3/15/1,2 St vz	CHF 2.20

CLEANFIX TW411 SEV

Saugmotor-Pumpe

PDF erstellt am: 06.03.2024 17:15



TW 411

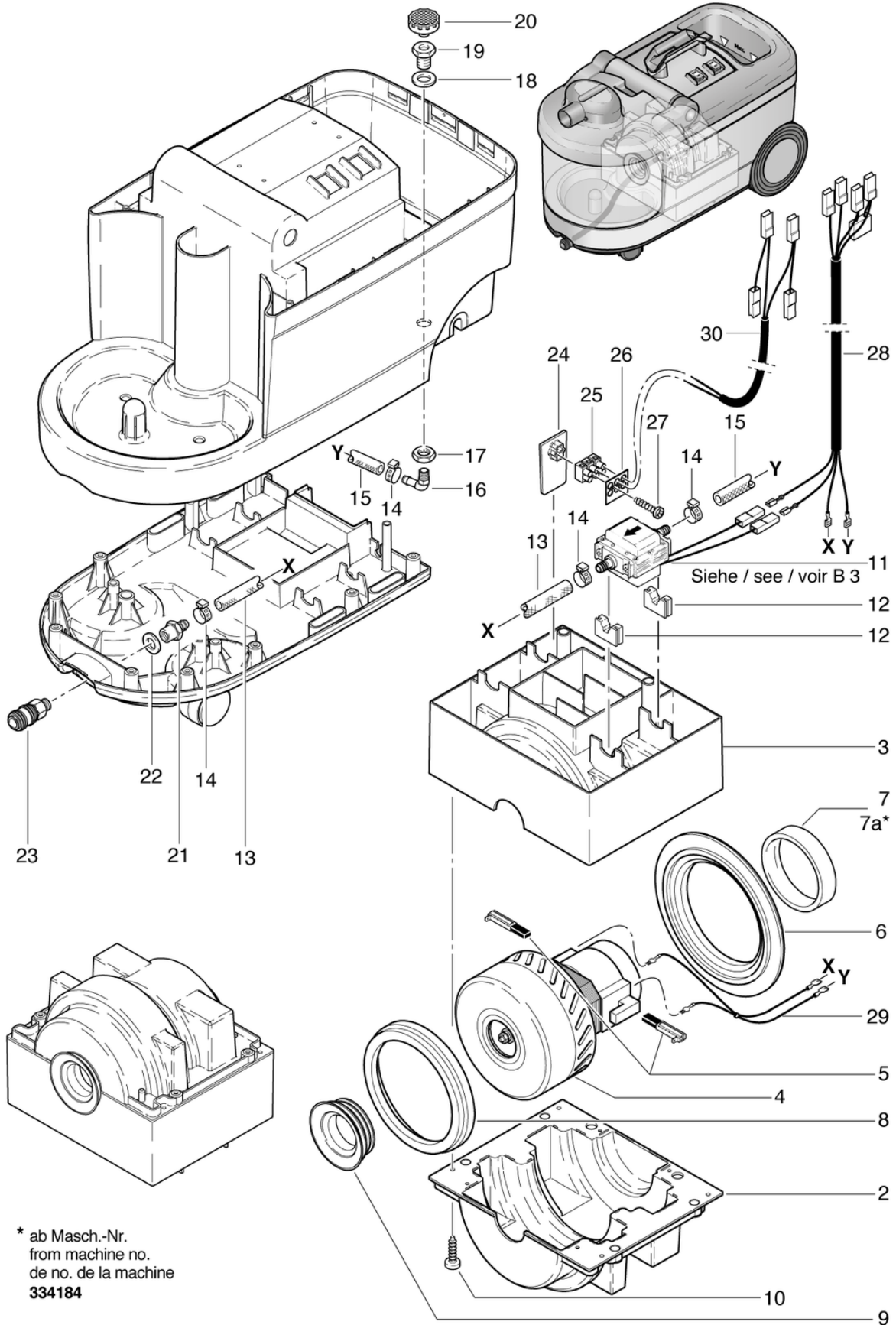

* ab Masch.-Nr.
from machine no.
de no. de la machine
334184

Pos.	Artikel-Nr.	Ersatzteil	Preis
2	043.602	Untere Motorenschale	CHF 22.25
3	043.601	Obere Motorenschale	CHF 27.45
4	P876	Saugmotor 230V/50 Hz, 1000 W	CHF 147.10
5	P876KB	Kohlebürsten (Paar)	CHF 25.50
6	043.606	Abdichtring ø 190 / 124 x 23,5	CHF 6.40
7a	043.604	Motorendichtung ø 80 x 6 x10.25	CHF 2.20
7	043.607	Motorendichtung ø 80 x 6 x 20.5	CHF 2.40
8	P971G	Turbinendichtung blau	CHF 10.70
9	043.605	Dichtung	CHF 3.90
10	P515Z	Schraube WN 1452 K50 x 16 St vz	CHF 2.20
11	P809	NDS-X-Pumpe 220-240V/50Hz	CHF 220.25
12	043.603	Pumpenhalter	CHF 2.20
13	043.609	Schlauch Pumpe - Kupplung	CHF 2.60
14	P550B	Schlauchklemme 15,7-706R	CHF 2.80
15	043.610	Schlauch Tank - Pumpe	CHF 0.00
16	P541H	Winkelnippel WES 8 / R1/4"	CHF 4.65
17	P535B	Mutter 3/8" Ms	CHF 2.20
18	P097	Dichtscheibe 30/17/2 PE	CHF 2.20
19	P535E	Hohlnippel 3/8" - 1/4" x 16 Ms	CHF 10.40
20	P106	Frischwasserfilter ND	CHF 17.50
21	P525K	Schlauchnippel NW8-1/4" Ms	CHF 6.75
22	P496A	Scheibe DIN 522 M12 13/30/1,6 St vz	CHF 2.20
23	P500B	Schnellkupplung 1/4" AG, gross Ms	CHF 24.65
24	043.608	Halter	CHF 2.20
25	P383A	Schraubklemme mit DS 3-pol. 2,5mm ²	CHF 3.20
26	P390	Bezeichnungsplättchen 500 BZ 3 Leer,N,L	CHF 2.20
27	P516F	Schraube WN 1451 K30 x 16 St vz	CHF 2.20
28	043.612	Kabelbaum Pumpe u. Motor	CHF 31.00
29	043.613	Kabelbaum Motor	CHF 6.05
30	043.614	Litzengarnitur	CHF 8.10

CLEANFIX TW411 SEV

NDSX-Pumpe

PDF erstellt am: 06.03.2024 17:15



TW 411 / TW 412

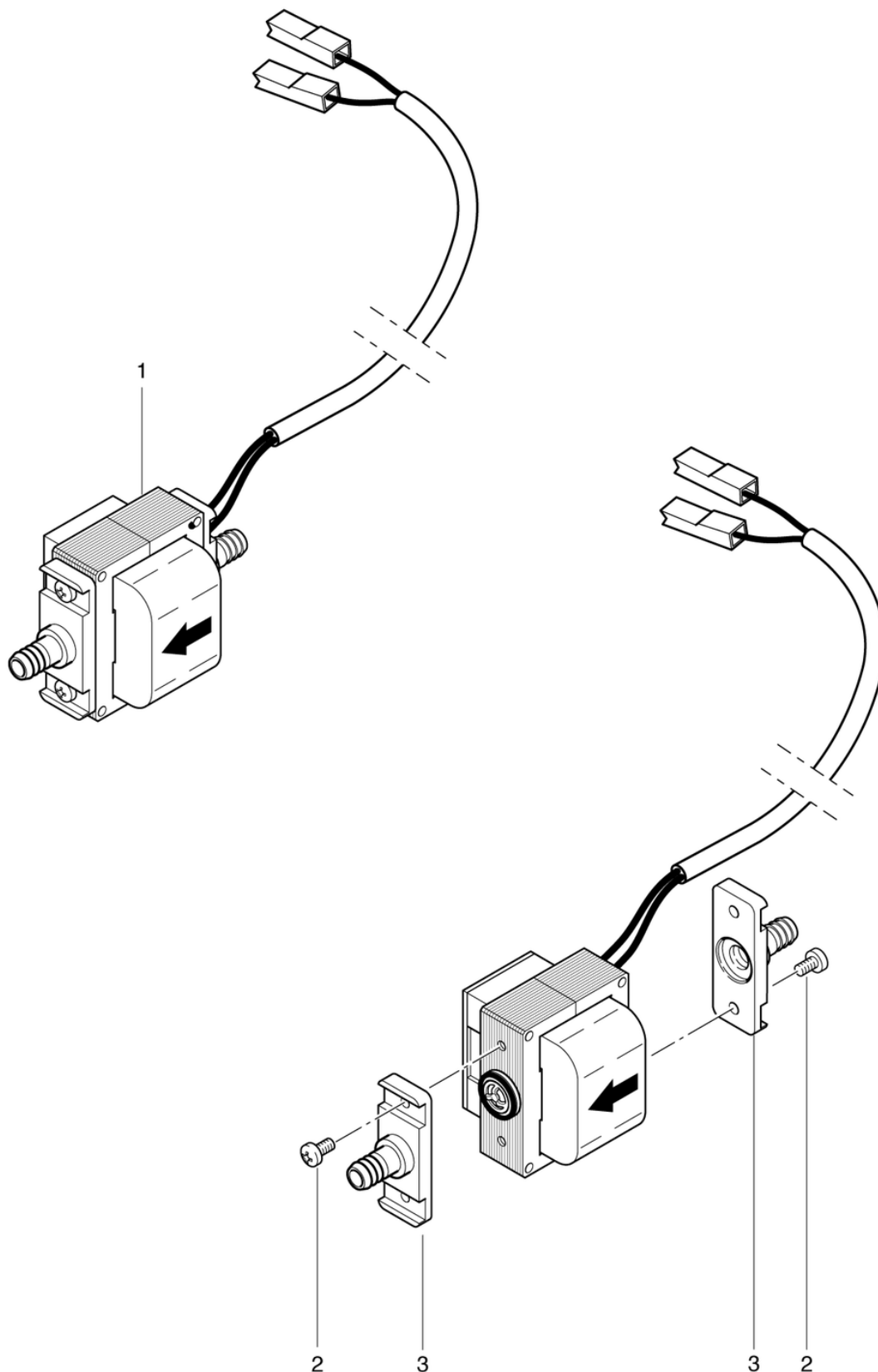

Pos.	Artikel-Nr.	Ersatzteil	Preis
1	P809	NDS-X-Pumpe 220-240V/50Hz	CHF 220.25
2	P481M	Schraube DIN 7985 M4 x 10 A2	CHF 2.20
3	P809M	Stutzen gerade ohne Gewinde	CHF 6.45

CLEANFIX TW411 SEV

Einbau Saugmotor-Pumpe und Netzzuleitung

PDF erstellt am: 06.03.2024 17:15



TW 411 / TW 412

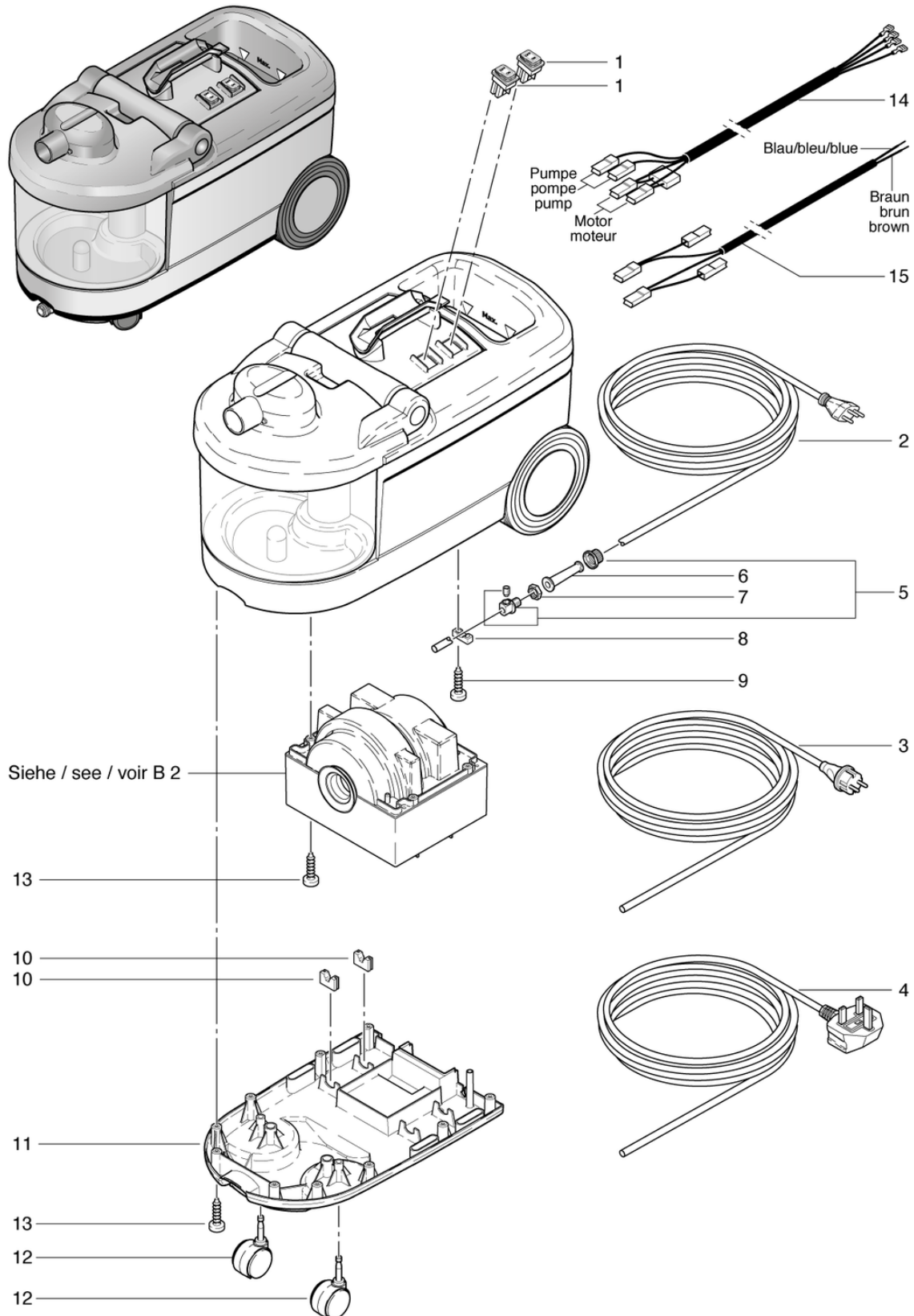

Pos.	Artikel-Nr.	Ersatzteil	Preis
1	P240	Wippenschalter orange 230V	CHF 15.05
2	P287	Netzkabel SEV 2 x 0,75mm ² , 7,5m	CHF 30.75
3	P288	Netzkabel VDE 2 x 0,75mm ² , 7,5m	CHF 30.75
4	P277	Netzkabel GB 2 x 1,0mm ² , 7,5m	CHF 49.00
5	P279	Zugentlastungsbride 2-teilig	CHF 4.25
6	P280	Knickschutztülle	CHF 2.20
7	P279H	Gegenmutter PG9 Ms vernickelt	CHF 2.20
8	4611085	Kabelbride anthrazitgrau	CHF 2.20
9	P516G	Schraube WN 1451 K40 x 16 St vz	CHF 2.20
10	043.603	Pumpenhalter	CHF 2.20
11	043.401	Boden anthrazitgrau	CHF 40.65
12	P204F	Lenkrolle ø50mm	CHF 5.05
13	P515Z	Schraube WN 1452 K50 x 16 St vz	CHF 2.20
14	043.612	Kabelbaum Pumpe u. Motor	CHF 31.00
15	043.614	Litzengarnitur	CHF 8.10

CLEANFIX TW411 SEV

Saugset

PDF erstellt am: 06.03.2024 17:15



TW 411

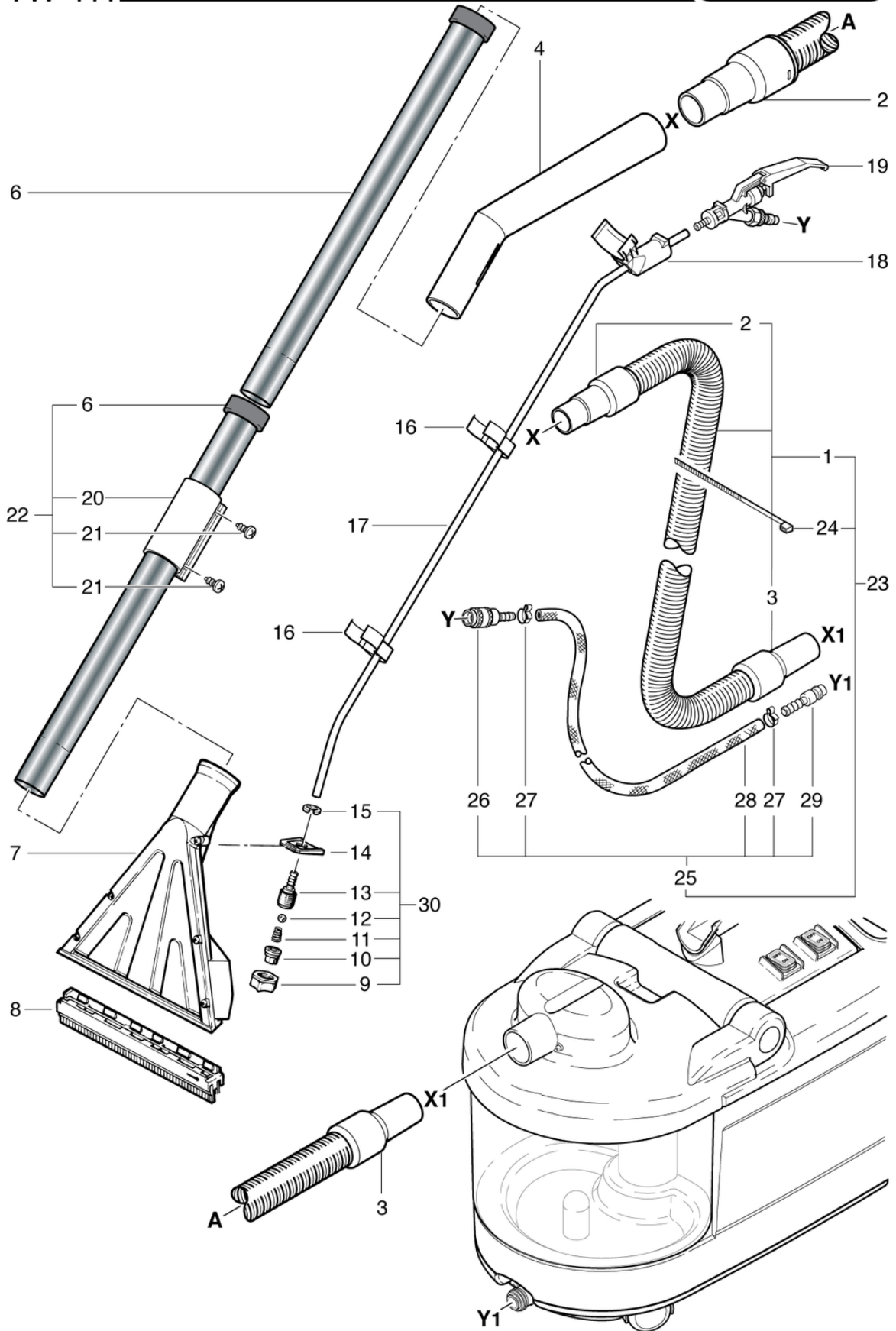

Pos.	Artikel-Nr.	Ersatzteil	Preis
1	043.561	Saugschlauch 2,2m	CHF 21.85
2	P575	Anschlussmuffe 32 abgesetzt	CHF 9.00
3	P562C	Muffe 32 (schraubbar)	CHF 10.70
4	606.010	Handrohr	CHF 33.95
6	645.002A	Chromstahlrohr	CHF 18.40
7	P600I	Saugdüse 23cm transparent	CHF 49.70
8	P600W	Hartbodenaufsatz zu 23cm-Düse	CHF 18.20
9	P602D	Überwurfmutter 3/8"	CHF 2.20
10	P602C	Sprühdüse weiss	CHF 2.20
11	P444E	Druckfeder 0,5/10,1;7/12	CHF 2.20
12	P172W	Kugel ø7,14 zu Sprühdüse PA6.6	CHF 2.20
13	P602E	Düsenhalter	CHF 2.20
14	P602I	Düsenhalterung	CHF 2.20
15	P499N	Scheibe DIN 6799 9/18,8/1,1 A2	CHF 2.20
16	P670	Haltespange	CHF 3.20
17	P665	PUR Sprühschlauch ø8/6 x 1,085m	CHF 9.30
18	606.020	Steckbride	CHF 13.55
19	900.681	Hebelventil mit Verschraubung	CHF 55.45
20	012.411	Gleitklemme	CHF 8.00
21	P515W	Schraube WN 1451 K40 x 8 St vz	CHF 2.20
22	645.003	Chromstahlrohr mit Gleitklemme	CHF 28.85
23	043.560	Saug-Sprühschlauch, 2,2m	CHF 70.20
24	P609	Kabelbinder schwarz 4,8 x 178mm	CHF 2.20
25	043.562	Sprühschlauch 2,2m	CHF 44.20
26	900.165	Wasserkupplung LW 6	CHF 26.10
27	P550I	Schlauchklemme 13,3-706R	CHF 2.50
28	043.563	Schlauch ø 6 / 12 x 2,25m	CHF 22.95
29	P501D	Stecknippel ø12 x 46mm Ms vern.	CHF 6.45
30	606.501	Sprühdüsen-Garnitur kpl.	CHF 21.80

CLEANFIX TW411 SEV

Stromlaufplan

PDF erstellt am: 06.03.2024 17:15



TW 411

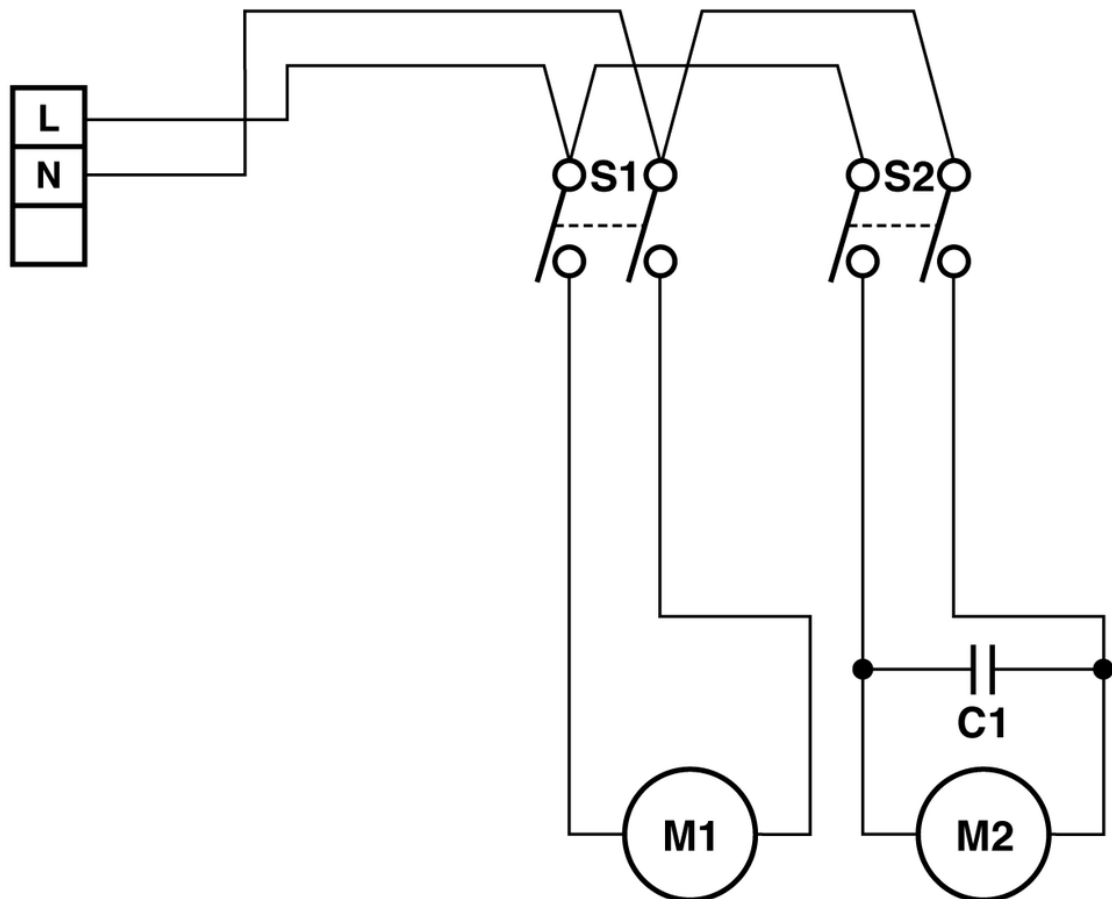

- S1 = Wippenschalter 230 V 1 / Interrupteur 230 V 1 / Valve-switch 230 V 1
- S2 = Wippenschalter 230 V 2 / Interrupteur 230 V 2 / Valve-switch 230 V 2
- C1 = Entstörkondensator 0,15 uF / Condensateur 0,15 uF / Capacitor 0,15 uF
- M1 = NDS-X-Pumpe 230 V / Pompe NDS-X-230 V / NDS-X-pump 230 V
- M2 = Saugmotor / Motuer d'aspiration / Vacuum motor